

- Senken
- Gewinde schneiden
- Bohren
- Reiben
- Lamage
- Filetage
- Perçage
- Alésage

20
2000



IFANGER

IFANGER AG
CH-8610 Uster
Tel. 044 943 16 16

Werkzeugfabrik
www.ifanger.com
Fax 044 943 16 17

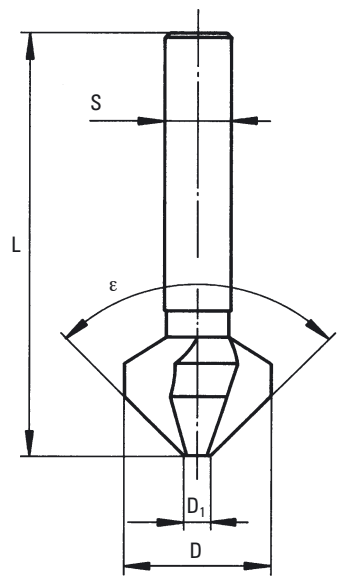
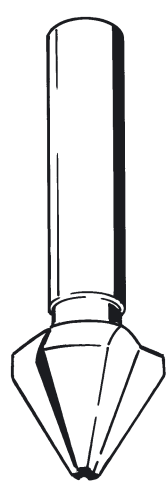
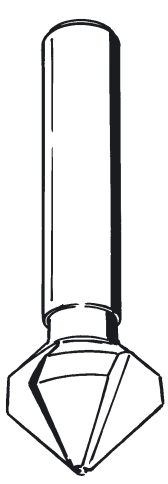
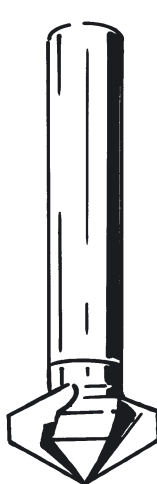
|  | | | | |  | |  | | |  |
|---|----------------------|---------|---------|---------------|---|-------------------------|--|-----------------------------|-------------------------|---|
| | | | | | HSS | Hartmetall Métal dur | HSS | HSS-TiN | Hartmetall Métal dur | HSS |
| Norm / Norme | | | | | DIN 334 | Werk / Usine | DIN 335 | DIN 335 | Werk / Usine | Werk / Usine |
| für Senkungen (siehe Seite 5) pour noyures (voir page 5) | | | | | — | — | SN 213.185 DIN 74/1 + 75 | SN 213.185 DIN 74/1 + 75 | — | — |
| ε | | | | | 60° | 60° | 90° | 90° | 90° | 120° |
| Katalognummer Numéro de catalogue | | | | | 3901 ... | 3905 ... | 3921 ... | 3928 ... | 3925 ... | 3941 ... |
| D mm | D ₁ mm | S mm | L mm | Ident.- N° | CHF/Stück CHF/pièce | CHF/Stück CHF/pièce | CHF/Stück CHF/pièce | CHF/Stück CHF/pièce | CHF/Stück CHF/pièce | CHF/Stück CHF/pièce |
| 4.3 | 1.3 | 4 | 40 | ... 043 | — | — | 12.60 | 16.50 | — | — |
| 5 | 1.5 | 4 | 40 | ... 050 | — | — | 12.20 | 16.90 | — | — |
| 5.3 | 1.5 | 4 | 40 | ... 053 | — | — | 12.50 | 16.90 | — | — |
| 5.8 | 1.5 | 5 | 45 | ... 058 | — | — | 12.60 | 16.90 | — | — |
| 6 | 1.0 | 6 | 50 | ... 060 | — | 23.70 | — | — | 23.70 | — |
| 6 | 1.5 | 5 | 45 | ... 060 | — | — | 12.60 | 16.90 | — | — |
| 6.3 | 1.5 | 5 | 45 | ... 063 | 13.40 | — | 12.60 | 16.90 | — | — |
| 7 | 1.8 | 6 | 50 | ... 070 | — | — | 13.20 | 19.65 | — | — |
| 7.3 | 1.8 | 6 | 50 | ... 073 | — | — | 13.90 | 19.65 | — | — |
| 8 | 2 | 6 | 50 | ... 080 | 13.90 | — | 13.90 | 19.65 | — | 14.— |
| 8.3 | 2 | 6 | 50 | ... 083 | — | — | 14.30 | 19.65 | — | — |
| 9.4 | 2.2 | 6 | 50 | ... 094 | — | — | 15.40 | 21.60 | — | — |
| 9.5 | 1.2 | 6 | 59 | ... 095 | — | 31.10 | — | — | 31.10 | — |
| 10 | 2.5 | 6 | 50 | ... 100 | 17.40 | — | 16.60 | 21.60 | — | — |
| 10.4 | 2.5 | 6 | 50 | ... 104 | — | — | 17.30 | 23.50 | — | — |
| 11.5 | 2.8 | 8 | 56 | ... 115 | — | — | 18.10 | 24.50 | — | — |
| 12.4 | 2.8 | 8 | 56 | ... 124 | — | — | 18.20 | 25.20 | — | — |
| 12.5 | 2.8 | 8 | 54 | ... 125 | — | — | — | — | — | 17.70 |
| 12.5 | 3.2 | 8 | 56 | ... 125 | 17.40 | — | — | — | — | — |
| 12.7 | 1.5 | 6 | 60 | ... 127 | — | 37.50 | — | — | 37.50 | — |
| 13.4 | 2.9 | 8 | 56 | ... 134 | — | — | 18.20 | 29.10 | — | — |
| 15 | 3.2 | 10 | 60 | ... 150 | — | — | 21.10 | 29.10 | — | — |
| 15.8 | 2 | 8 | 58 | ... 158 | — | 52.— | — | — | 52.— | — |
| 16 | 3.2 | 10 | 57 | ... 160 | — | — | — | — | — | 23.20 |
| 16 | 4 | 10 | 63 | ... 160 | 22.80 | — | — | — | — | — |
| 16.5 | 3.2 | 10 | 60 | ... 165 | — | — | 22.60 | 30.70 | — | — |
| 19 | 3 | 8 | 65 | ... 190 | — | 70.60 | — | — | 70.60 | — |
| 19 | 3.5 | 10 | 63 | ... 190 | — | — | 30.60 | 41.40 | — | — |
| 20 | 3.5 | 10 | 59 | ... 200 | — | — | — | — | — | 33.10 |
| 20 | 5 | 10 | 67 | ... 200 | 32.30 | — | — | — | — | — |
| 20.5 | 3.5 | 10 | 63 | ... 205 | — | — | 31.10 | 42.70 | — | — |
| 23 | 3.8 | 10 | 67 | ... 230 | — | — | 40.10 | — | — | — |
| 25 | 3.8 | 10 | 63 | ... 250 | — | — | 42.40 | 58.— | — | 43.90 |
| 25 | 6.3 | 10 | 71 | ... 250 | 43.60 | — | — | — | — | — |
| 28 | 4 | 12 | 71 | ... 280 | — | — | 58.60 | 70.50 | — | — |
| 31 | 4.2 | 12 | 71 | ... 310 | — | — | 63.30 | 75.— | — | — |

Bestell-Nr.: Entsprechende Katalognummer und Ident.-N° in dieser Reihenfolge zusammenfügen, z. B.: 3921 043

N° de commande: Joindre dans cet ordre au numéro de catalogue le Ident. N°, par exemple 3921 043



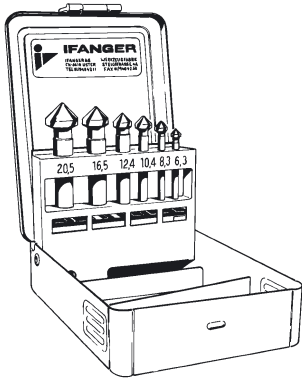

| | | | | | | |
|--|---|------------|-------------|--------------------|-------------|-------------|
| |  | | | | | |
| | HSS | | | HSS-TiN | | |
| Typ Type | Für Senkungen nach SN 213.185 und DIN 74, Blatt 1, Bf-4 Pour noyures selon SN 213.185 et DIN 74, feuille 1, Bf-4 | | | | | |
| Schaft / Tige | zyl. / cyl. | | | | | |
| ∠ε des Senkers / ∠ε de la fraise | 90° | | | | | |
| bestehend aus Senkern ∅ D mm contenant fraises ∅ D mm | 6,3 | 8,3 | 10,4 | 12,4 | 16,5 | 20,5 |
| für Gewinde pour filetage | M3 | M4 | M5 | M6 | M8 | M10 |
| Katalognummer / Numéro de catalogue | 3991 000 (HSS) | | | 3998 000 (HSS-TiN) | | |
| CHF/Stück / CHF/pièce | 130.— | | | 172.50 | | |

Bestell-Nr. = Katalognummer

N° de commande = N° de catalogue

Reduzierhülsen

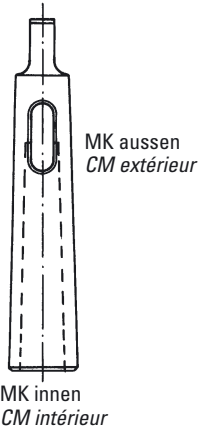
Douilles de réduction

| | | | | | |
|---|-----------|--|-----------------------|-----------------------|-----------------------|
|  | |  | | | |
| Norm / Norme | | DIN 2185 | | | |
| MK aussen / CM extérieur | | 2 | 3 | 4 | 5 |
| Katalogbezeichnung Désignation de catalogue | | RED-2/... | RED-3/... | RED-4/... | RED-5/... |
| MK innen / CM intérieur | Ident.-N° | CHF/Stück – CHF/pièce | CHF/Stück – CHF/pièce | CHF/Stück – CHF/pièce | CHF/Stück – CHF/pièce |
| 1 | .../1 | 17.— | 22.70 | 32.10 | — |
| 2 | .../2 | — | 21.20 | 31.10 | 53.50 |
| 3 | .../3 | — | — | 31.10 | 53.50 |
| 4 | .../4 | — | — | — | 53.50 |

Bestell-Nr.: Entsprechende Katalogbezeichnung und Ident.-N° in dieser Reihenfolge zusammenfügen, z. B.: RED-2/1

N° de commande: Joindre dans cet ordre à la désignation de catalogue le Ident. N°, par exemple RED-2/1