

GRS

Thread Relief Tools GRS of HSS-CO (Kob), HSS (Rap), TiN-coated and with Carbide Tips

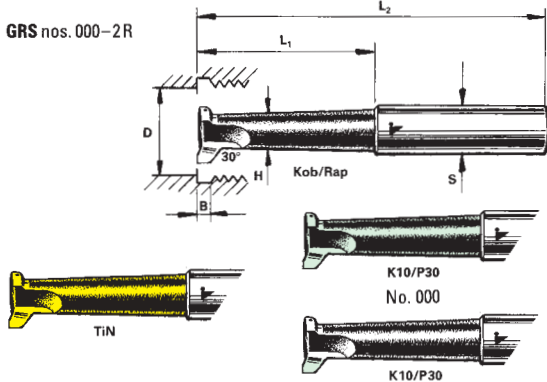

Heads: GRS nos. 3-11 R
Shanks see page 12

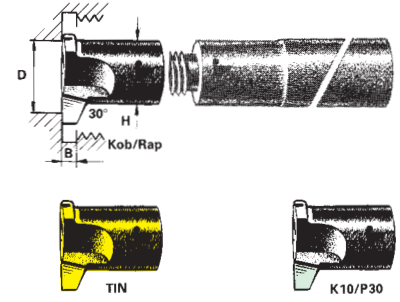

How to order (example): 5 pieces GRS-1-R-TiN No. 00-2

Size GRS	Code number for righthand-side cutting (for lefthand-side cutting replace "R" by "L")	Availability								Recomm. minimum bore D / mm	Width B mm	Ø of neck H mm	Ø S-h7 of shank mm	Thread	Length of neck L ₁ mm	Total length L ₂ mm	
		"R"				"L"											
		Kob	Rap	TiN	K10	P30	Kob	TiN	K10	P30							
000	GRS-000-R...	●	●	●	●	●	○	○	○	○	5	1.3	2.6	8	—	15	46
00	GRS-00-R...	●	●	●	●	●	○	○	○	○	6.5	1.5	3.5	8	—	20	50
0	GRS-0-R...	●	●	●	●	●	○	○	○	○	9	1.8	4.8	8	—	26	52
1	GRS-1-R...	●	●	●	●	●	○	○	○	○	11	2	6	8	—	28	56
2	GRS-2-R...	●	●	●	●	●	○	○	○	○	13	2.2	7.5	8	—	—	64
3	GRS-3-R...	●	●	●	●	●	○	○	○	○	17	2.5	10	M6			
4	GRS-4-R...	●	●	●	●	●	○	○	○	○	21	2.7	12	M8			
5	GRS-5-R...	●	●	●	●	●	○	○	○	○	24	3	14	M10×20TPI			
6	GRS-6-R...	●	●	●	●	●	○	○	○	○	28	3.5	16.3	M12×20TPI			
7	GRS-7-R...	●	●	●	●	●	○	○	○	○	31	4	18.3	M14×20TPI			
8	GRS-8-R...	●	●	●	●	●	○	○	○	○	34	4.5	20	M15×20TPI			
10	GRS-10-R...	●	●	●	●	●	○	○	○	○	42	5	25	M18×20TPI			
11	GRS-11-R...	●	●	●	●	●	○	○	○	○	50	5.5	30	M21×14TPI			

▲ Please indicate here alloy or grade of carbide required

SEN

Circlip Groove (Retaining Ring) Tools SEN of HSS-CO (Kob), HSS (Rap), TiN-coated or with Carbide Tips for Circlip Grooves According to DIN 472

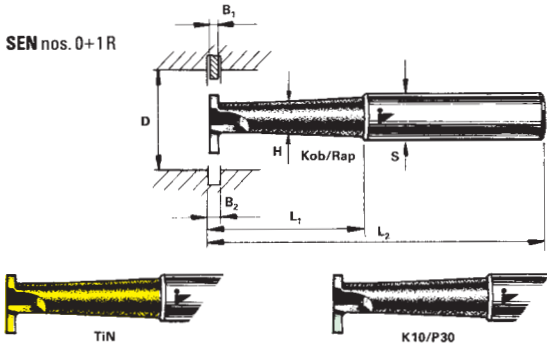

Heads: SEN nos. 3-8 R
Shanks see page 12

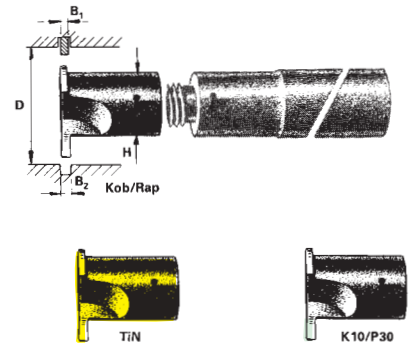

How to order (example): 5 pieces SEN-1-R-1.0-Kob.

Size SEN	Code number for righthand-side cutting (for lefthand-side cutting replace "R" by "L")	Availability								Circlip thickness B ₁ mm	Width of groove B ₂ -H13 mm	For bore D mm	Ø of neck H mm	Ø S-h7 of shank mm	Thread	Length of neck L ₁ mm	Total length L ₂ mm	
		"R"				"L"												
		Kob	Rap	TiN	K10	P30	Kob	TiN	K10	P30								
0	SEN-0-R-0.8...	●	●	●	●	●	○	○	○	○	0.8	0.9	8-9	4	8	—	22	52
1	SEN-1-R-1.0...	●	●	●	●	●	○	○	○	○	1.0	1.1	10-16	6	8	—	25	55
3	SEN-3-R-1.0...	●	●	●	●	●	○	○	○	○	1.0	1.1	17-22	10	M6			
4	SEN-4-R-1.2...	●	●	●	●	●	○	○	○	○	1.2	1.3	23-33	12	M8			
6	SEN-6-R-1.5...	●	●	●	●	●	○	○	○	○	1.5	1.6	34-39	16.3	M12×20TPI			
6	SEN-6-R-1.75...	●	●	●	●	●	○	○	○	○	1.75	1.85	40-49	16.3	M12×20TPI			
8	SEN-8-R-2.0...	●	●	●	●	●	○	○	○	○	2.0	2.15	50-64	20	M15×20TPI			
8	SEN-8-R-2.5...	●	●	●	●	●	○	○	○	○	2.5	2.65	65-82	20	M15×20TPI			
8	SEN-8-R-3.0...	●	●	●	●	●	○	○	○	○	3.0	3.15	85-100	20	M15×20TPI			
8	SEN-8-R-4.0...	●	●	●	●	●	○	○	○	○	4.0	4.15	102-200	20	M15×20TPI			

▲ Please indicate here alloy or grade of carbide required

Availability: ● ex stock / ○ within short notice

